

S300 Series Dust Monitors

- S301 – DustGuard
- S303 – Trend Monitor
- S304 – Emission Monitor
- S305 – Stack Monitor
- Intrinsically Safe (ATEX) Dust Monitors
- Split Architecture (Remote) Models
- Data Logging Software



DUST MONITORS – WITH A DIFFERENCE!

- Automatic Range setup
- No manual adjustment required
- Automatic drift compensation
- Colour of particles will not affect the reading
- No optical windows to be kept clean
- Buildup of dust on the probe will not affect monitoring
- No alignment required
- Vibration has no effect on the reading

Features

	S301	S303	S304	S305
2 Independent alarm relays (user selectable alarm limits, NO or NC)	•	•	•	•
4–20 mA signal output		•	•	•
Remote setup & configuration		○	○	○
Self zero check				•
Span check				•
Filter bag leak detection. ON-OFF systems. Pneumatic transport	•	•	•	•
Trend monitoring. Filter performance		•	•	•
Filter performance. Particulate emissions		•	•	•
Stack monitoring. Can be calibrated to mg/m ³			•	•
Serial communication			•	•
ATEX approved model	x	x	x	x
Remote models	•	•	•	•

• Standard ○ Optional x Available



S300 Series Dust Monitors

S301 is designed as a filter bag leak detection monitor. Equipped with two independent alarm relays which can be used for early warning and failure, or connected to alarm-devices, it is used to detect filter deterioration and blockage or breakage. The alarms can be used for process control (as an ON-OFF system) in flow – no flow situations in bulk solids handling and pneumatic transport applications. Very fast response time, a typical characteristic of these monitors, enables early detection and prevention of expensive product loss to the environment.

S303 has also a 4–20 mA analog signal output used for trend monitoring. It is installed downstream of a filter, cyclone, dryer, or similar devices to monitor the filter performance as well particulate emissions. It has two alarm relays which will energise when the amount of particulate in the gas stream exceeds a preset level. It can also be used for process control in certain applications. **S301** and **S303** are designed for use in any process fitted with bag, ceramic, or cartridge filters or cyclones where indicative (qualitative) monitoring is required.

S304

- Linear monitor for dust emission monitoring
- Automatic range setup
- Automatic drift compensation
- Can be calibrated to mg/m^3 (dust concentration)
- Remote configuration
- Remote data collection via data-logging software
- PIN code protection

S305

- Linear monitor for stack-monitoring applications
- Automatic range setup
- Automatic drift compensation
- Can be calibrated to mg/m^3 (dust concentration)
- Remote configuration and data collection
- TÜV Certificate: BlmSchV 13, BlmSchV 17, BlmSchV 27, BlmSchV 30 and TA Luft 2002
- Self Zero check and self Span check
- PIN code protection

ATEX MODELS

- Certified for ATEX Zone 20, 21 or 22
- Approved to Category II 1/2 for Gas and Dust
- IP 65 Enclosure, Custom Designed
- Certification Type: II 1/2 GD EEx ia IIC, T6, IP65, 85°C
- Utilising SINTROL's Advanced Dust Detection Technology

The ATEX Directive covers health and safety of workers potentially at risk from exposure to explosive environments. This Directive classifies areas into Zone 0, 1, 2 for gas and 20, 21 or 22 for dust and ensures that only ATEX certified systems are installed in the areas. Products are required to be categorised by the level of protection that they offer against the risk of them becoming a potential source of ignition in an explosive atmosphere. The equipment conformity categories are 1, 2 & 3.

REMOTE DISPLAY



D400
– Remote digital display supplied with S300 Series Monitors (optional)

SPLIT ARCHITECTURE (REMOTE) MODELS

S300 Series include the following remote models: S311, S313, S314 and S315. The remote models are used when the sensor has to be installed on a pipe, duct or stack but the control unit up to 200 meters away in control room. In these models, the sensor is connected to an enclosure housing the preamplifier (PA) and the amplified signal is transmitted with a 4-wire shielded cable using one of the recommended cables.

DATALOGGING AND CONFIGURATION SOFTWARE

- Datalogging and configuration software for alarm logging and emission reporting.
- Hourly, daily or monthly averages can be generated from logged data.
- Read out, configure and send the parameters back to the monitor.
- Start monitor's autoseup procedure from software.
- Up to 20 simultaneous channels can be seen in user interface, channel number can be multiplied with several sessions of software.
- Online trend view with zoom and pan.
- Analog mA, serial or ethernet connection

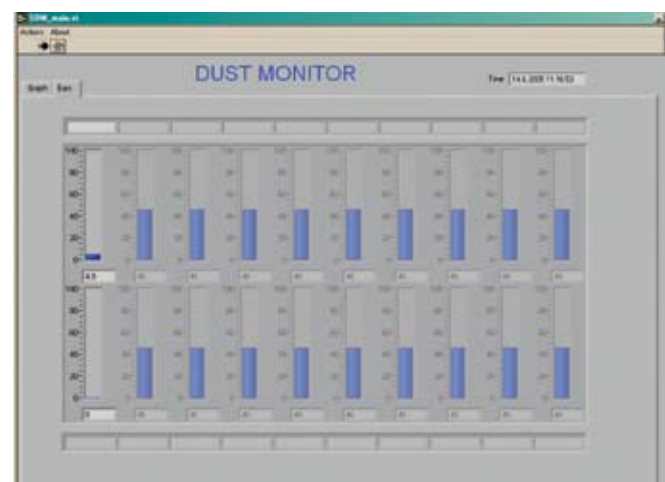

Up to 20 channels simultaneously.

Principle of Operation

In the S300 series monitors DC component of the signal is mathematically filtered out and stored for use if required. Only the AC component of the signal is used for monitoring solid particles. The signal is obtained by the particles impacting the sensor rod or passing nearby. Both modes of charge transfer, impaction and induction contribute towards the signal acquisition. The monitor is not affected by particle buildup on the probe.

THE AUTOMATIC SETUP PROCEDURE

S300 Series dust Monitors utilise a unique method of detecting dust particles. The received signal is analysed in the 16-bit microcontroller of the monitor over a period of time and the average value determined. The monitor then selects the right range itself. **No manual range setup is required.**

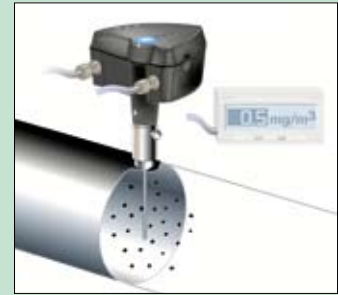

Comparison of the Signal Output from S304/S305 and an Optical Dust Monitor

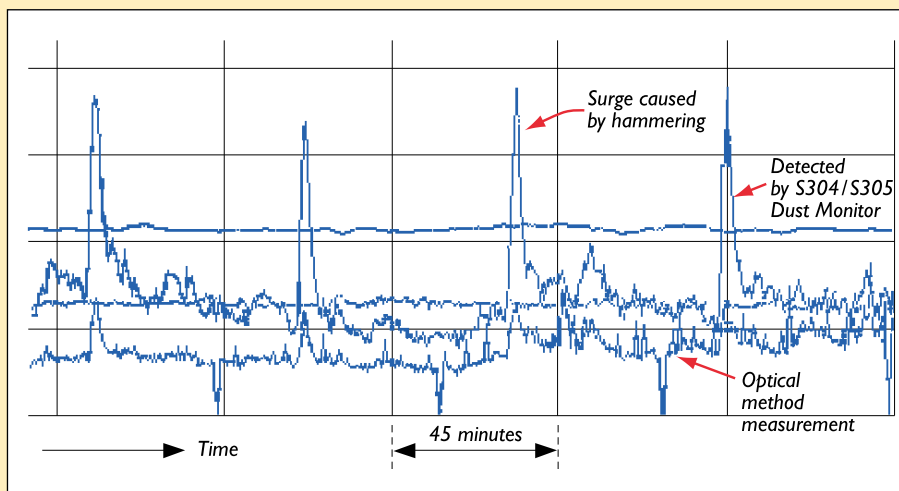

Process conditions:

Dust concentration: 25 mg/Nm³
 Dust weight ratio: 1.3
 Velocity: 10 m/s
 Relative humidity: 10 ~ 20 vol%
 Temperature: 50 ~ 180 °C
 Pressure: 20 mm H₂O
 Duct size: 2x2 m
 Installed 50 meters downstream of the electrostatic precipitator

Data is presented from parallel testing of a S304/S305 dust monitor and an optical monitor both installed downstream of an electrostatic precipitator (ESP) in a cement plant. Peaks in the signal outputs from the instruments correspond to “hammering” of the ESP which is carried out periodically to remove the particulate matter from the precipitating elec-

trode. Fast response time of the S304/S305 is one of the excellent characteristics of these dust monitors. With no optical “windows” to be kept clean and no problem of the alignment of the light axis, S304 and S305 proved to be an excellent choice for monitoring of dust in the stack of the cement plant.

TESTS AND TEST RESULTS

Extensive tests carried out with different types of particulate matter in Finland and Germany showed S304/S305’s excellent linearity with various dust types. The particulates used included test dusts with known particle size distributions as well as ash from coal fired power plants. The Figure, shows the linearity of these monitors for a typical dust. (Particle size: 1–10 microns).

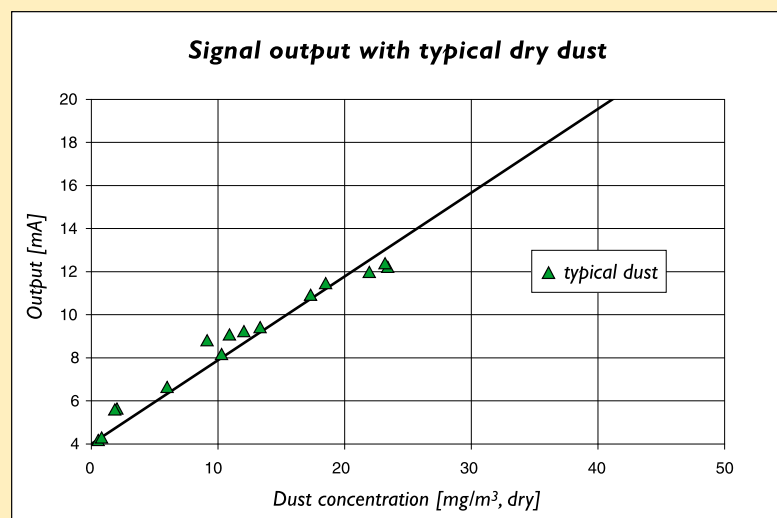

Typical Applications

- Cement manufacture
- Chemical processing
- Metals industry
- Foundries
- Pharmaceutical industry
- Mineral drying
- Fertilisers
- Wood processing
- Food and tobacco
- Rubber compounding
- Animal feed processing
- Power plants
- Waste incinerators
- Pulp and paper

TYPICAL TREND-MONITORING APPLICATION (Dryers)

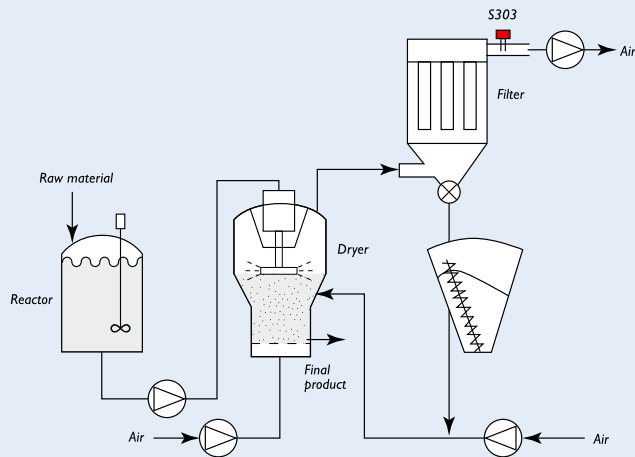

The schematic diagram shows an application where S300 series dust monitors are installed after a filtration system to monitor the solid flow continuously downstream of the filters and also to detect leakage or filter breakage.

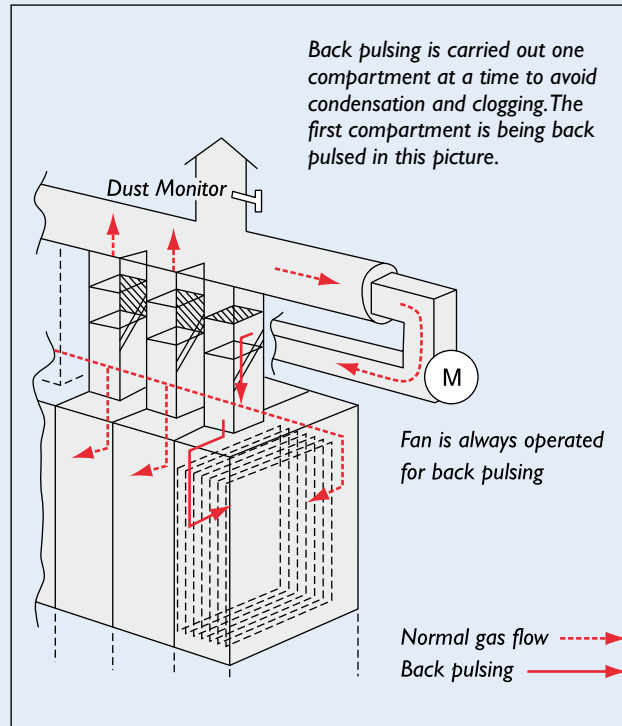

Trend monitoring data shows that there is a correlation between dust concentration and signal output of the S303 Dust Monitor. This dust monitor was operated for several months without maintenance.

FOUNDRY

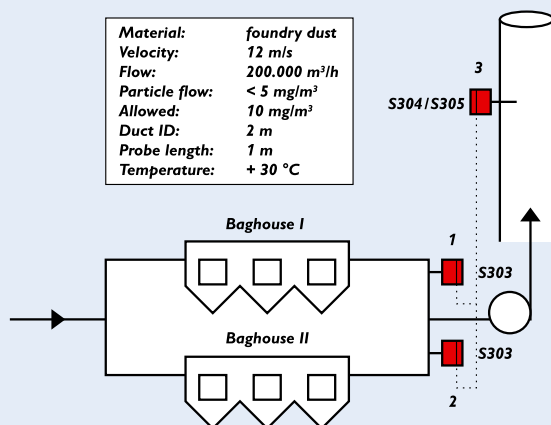

S300 dust monitors are installed after the baghouses (or electrostatic precipitators in some cases) to monitor these particulate arrestment systems. The continuous mA signal outputs at points 1 and 2 give information on filter wear and tear. The S304/S305 installed at point 3 is used to measure the total emission of foundry dust, i.e. for stack-monitoring.

A reliable and accurate dust monitoring system is needed to satisfy the continuous monitoring requirements of the environmental regulatory authorities and to ensure compliance with increasingly stringent standards imposed for particulate emissions to the atmosphere. Sintrol's S304 and S305 dust monitors are proving an ideal solution for stack-monitoring requirements of a variety of applications including coal-fired power plants and incinerators. TÜV certification includes: 13 BlmSchV, 17 BlmSchV, 27 BlmSchV, 30 BlmSchV and TA Luft 2002.

DUST MEASUREMENT OF COAL-FIRED POWER PLANT FLUE GAS WITH S300 SERIES DUST MONITORS

Flue gases from pulverized coal fired power plants contain particulate matter that have to be removed to comply with stringent environmental regulations. Electrostatic precipitators (ESP) are used for this purpose. Continuous monitoring of particulate matter in the flue gas is needed

to maintain high efficiency of the ESP and to detect its abnormal operation. S304 and S305 dust monitors are used for this purpose because of their excellent characteristics and easy maintenance.

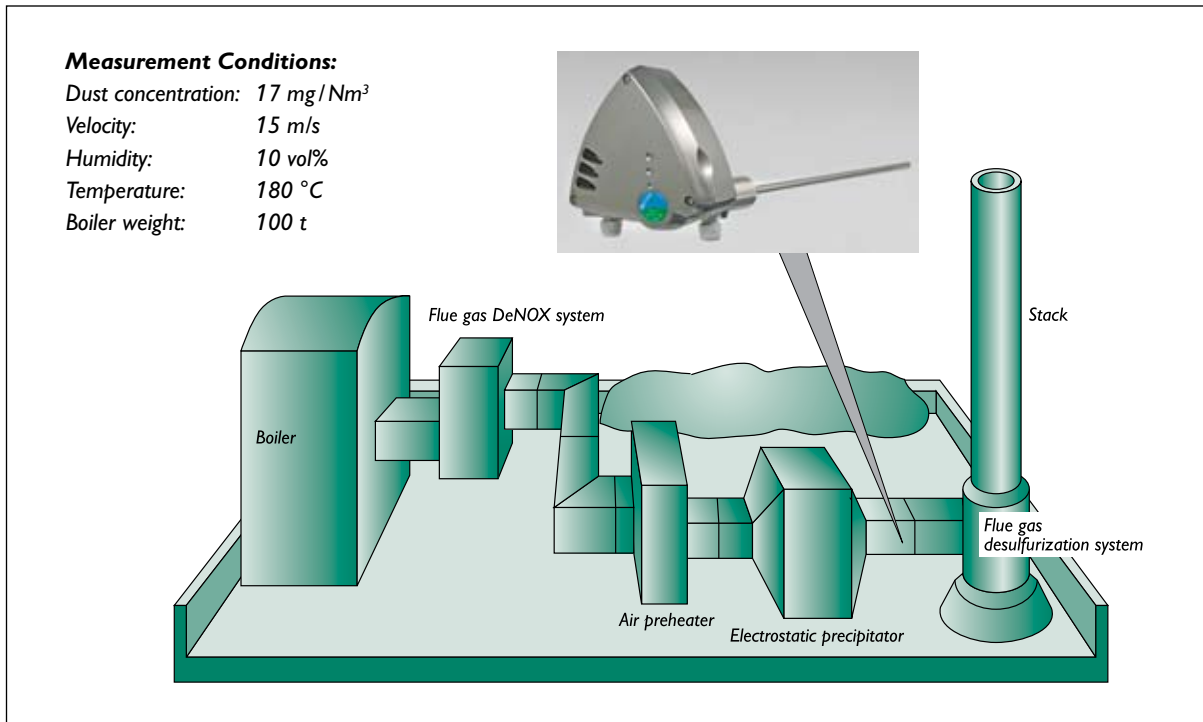

DUST MEASUREMENT OF CEMENT KILN'S EXHAUST GAS WITH S300 SERIES DUST MONITORS

The exhaust gases from a cement manufacturing plant contain particulate matter that have to be removed to comply with stringent environmental regulations. Electrostatic precipitators (ESP) are used to reduce the par-

ticulate matter to an acceptable level. S304 and S305 dust monitors are used to monitor the ESP as well as the particulate matter downstream of the ESP.

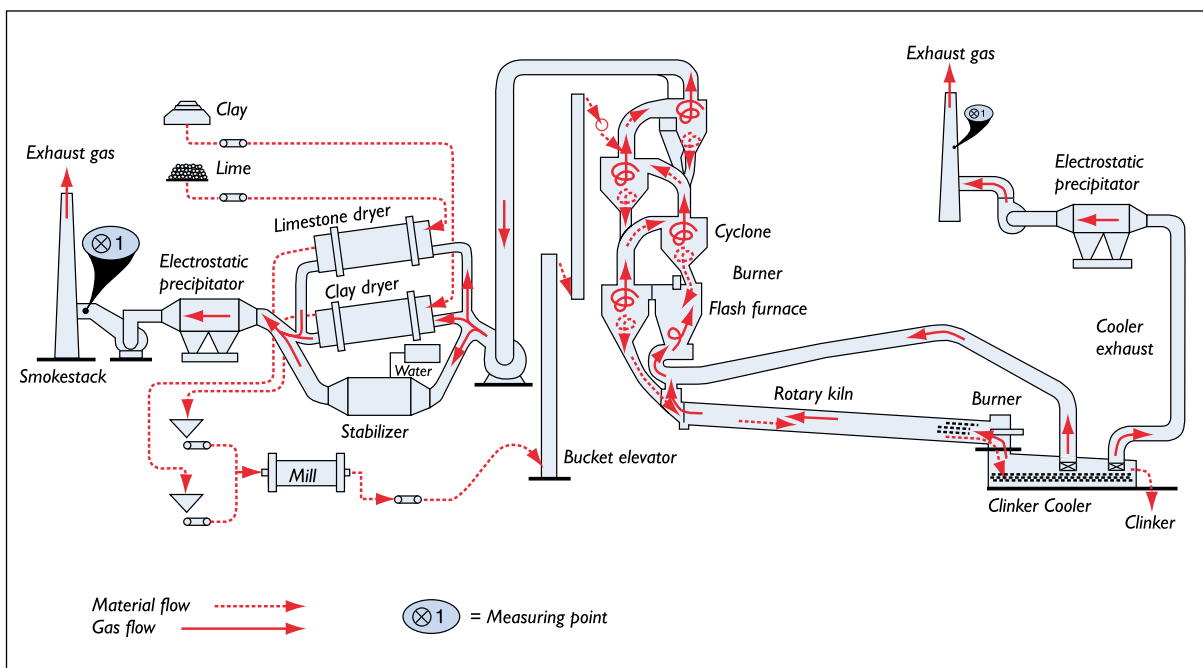

S300 Series Dust Monitors

TECHNICAL SPECIFICATION

Measurement objects: Solid particles in a gas flow
 Particle size: 0.3 µm or larger
 Measurement range: approx. 0.1 mg/m³ to 1 kg/m³

Process Conditions:
 Temperature: 300°C (standard),
 700°C (high temperature)
 Pressure: Max. 2 bar
 Gas velocity: Min. 4 m/s
 Humidity: 95 % RH or less (non-condensing)
 Input surge voltage: Max. 100 V

Measurement principle: electrostatic detection and electric induction

Analog damping time constant: 10 to 180 seconds,
 (10-300 s optional)

Output signals: isolated 4-20 mA depend on model
 relay 5 A, 24 V AC/DC all models
 serial communication depend on model

Ambient conditions:
 Temperature: -20 to + 45°C and 60°C for 24 VDC
 Humidity: 95% RH (non-condensing)
 Vibration: 5 m/s² or less

Materials:
 Sensor rod: stainless steel (AISI316)
 Insulation of sensor: PEEK (HT: klinger)
 Enclosure /casing: aluminium alloy

Power Supply: 100 or 115 or 230 VAC, 24 VDC

Power consumption: Max. 3W DC model,
 Max. 8W AC model

Wiring connections: DIN PG11 cable gland for power supply
 DIN PG11 cable gland for output signals

Weight: 2.3 kg

RANGE SETUP:
 Normal measuring range: – automatic, based on average measured dust flow during setup procedure
 Extended measuring range – user selectable (optional)

RELAY ALARM OPTIONS:
 Alarm level: – automatic, set at factory (based on average measured dust flow) or user selectable fixed ranges
 Software alarm option: Configurable via data logging software

Offset trim: automatic drift compensation

Dimensions

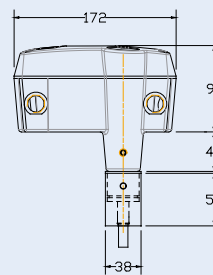

Picture 1. Enclosure

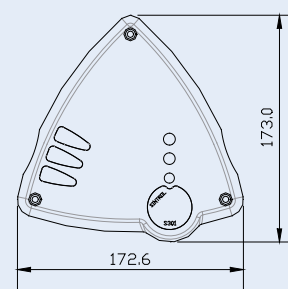

Picture 2. Cover

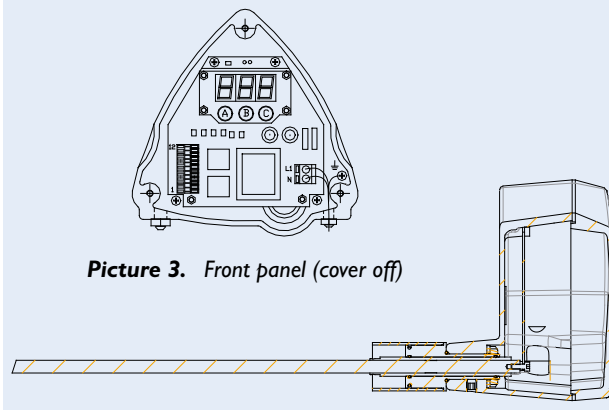

Picture 3. Front panel (cover off)

Ordering codes for S300 monitors

Temperature (°C)	
3	300
7	700
Pressure	
L	< 2 bar
H	> 2 bar
Voltage	
1	230 VAC
2	115 VAC
3	24VDC
Air purge	
N	without air purge
Y	with air purge
Probe length (mm)	
1	250
5	500
7	750
9	1000
Options	
R	with remote display
Process connection	
S	Standard
Q	Quick clamp
F	Flange
x	x
x	x
x	x
x	x
æ	x
x	x
x	x

e.g. S304-3L1Y5RS : (300 °C, < 2 bar, 230 VAC, with air purge, 500 mm probe, remote display, standard process connection)

CONTACTS:

SINTROL

Ruosilantie 15,
 FI-00390 Helsinki, FINLAND
 Tel. +358 9 561 7360
 e-mail: info@sintrol.com
 www.sintrol.com